

PINT SIZE TABLE RUNNER

— May —

KITS available from
ShabbyFabrics.com
while supplies last

PLEASE NOTE

All seams are $\frac{1}{4}$ "

WOF = Width of Fabric

RST = Right Sides Together

REQUIRED MATERIALS

- 4" x 10" lavender floral sprigs for **HST (Fabric A)**
- 4" x 10" dark purple floral sprigs for **HST and cornerstone (Fabric B)**
- 8" x 14" purple tonal floral for **basket (Fabric C)**
- $\frac{1}{3}$ yard cream with tan dot for **piecing and appliqué backgrounds (Fabric D)**
- 4" x 14" green tonal flower groups for **sashing (Fabric E)**
- 7" x WOF green texture for **binding (Fabric F)**
- 27" x 21" for **backing**
- various scraps for appliqué
- fusible webbing

CUT FABRICS

From lavender floral sprigs (**Fabric A**), cut:

- (2) $3\frac{1}{2}$ " x $3\frac{1}{2}$ " squares for **HST**

From dark purple floral sprigs (**Fabric B**), cut:

- (2) $3\frac{1}{2}$ " x $3\frac{1}{2}$ " squares for **HST**
- (1) 1" x 1" square for **cornerstone**

From purple tonal floral (**Fabric C**), cut:

- (4) $3\frac{1}{2}$ " x $3\frac{1}{2}$ " squares cut in half diagonally \square for **basket**
- (4) $1\frac{1}{2}$ " x $2\frac{1}{2}$ " rectangles for **basket base right**
- (4) $1\frac{1}{2}$ " x $1\frac{1}{2}$ " squares for **basket base left**

From cream with scattered tan dot (**Fabric D**), cut:

- (2) $5\frac{7}{8}$ " x $5\frac{7}{8}$ " squares cut in half diagonally \square for **basket handle appliqué**
- (2) $5\frac{1}{2}$ " x 13" rectangles for **appliqué background**
- (8) $4\frac{1}{2}$ " x $1\frac{1}{2}$ " rectangles for **beside basket**
- (4) $2\frac{1}{2}$ " x $2\frac{1}{2}$ " squares for **below basket**

From green tonal flower groups (**Fabric E**), cut:

- (4) 1" x $6\frac{1}{2}$ " rectangles for **sashing**

From green texture (**Fabric F**), cut:

- (2) $2\frac{1}{2}$ " x WOF strips for **binding**

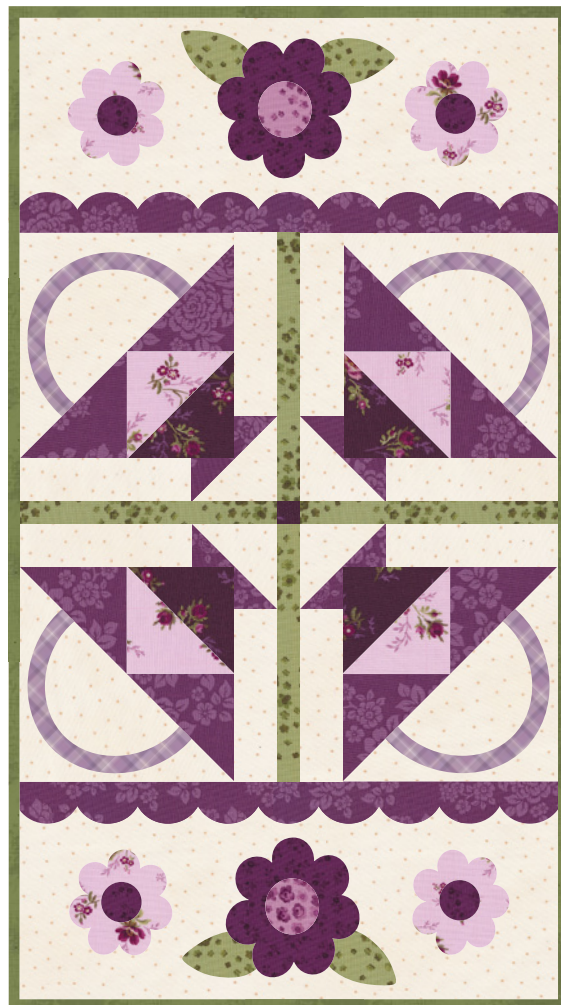

Finishes to: 13" x 23"

RECOMMENDED PRODUCTS

- Creative Grids $4\frac{1}{2}$ " x $8\frac{1}{2}$ " Ruler #CGR48
- Creative Grids $6\frac{1}{2}$ " x $24\frac{1}{2}$ " Ruler #CGR24
- Wafer 1 Lightbox
- Appli-Fuse Silicone Mat - 12" x 18"
- Wool Pressing Mat
- Pint Size Table Runner Series Kit - May - 3pc Thread Set

All available at ShabbyFabrics.com

As seen on the
**PINT SIZE TABLE RUNNER
SERIES - MAY**
video featured on our YouTube channel:



[YouTube.com/Shabby Fabrics](https://www.youtube.com/ShabbyFabrics)

APPLIQUÉ

NOTE: With the exception of the center flower and leaves, the appliqué design is symmetrical, so there is no need for a reverse diagram when tracing shapes for fusible appliqué. (*Reversed center flower and leaves shapes are provided for tracing.*)

Gently peel fusible paper from the back of each shape. Refer to Assembly Diagram to arrange shapes on **basket appliqué triangles** and **appliqué background fabric**.

Appliqué in place using the method and stitch of your choice.

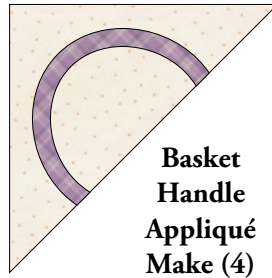

Basket Handle Appliqué
Make (4)

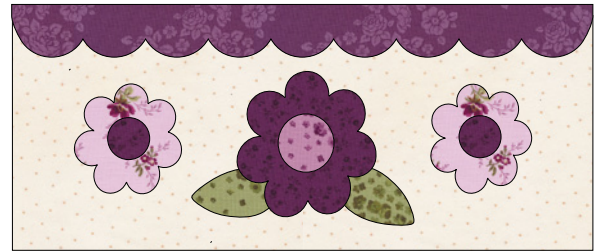

Appliqué - Make (2)

HALF SQUARE TRIANGLES

STEP 1: On the back of (1) A square, draw a line diagonally from corner to corner.

STEP 2: Layer this square and (1) 3½" x 3½" B square, RST, making sure to line up the edges.

STEP 3: Sew ¼" on both sides of the drawn line.

STEP 4: Cut on the drawn line. Press open.

STEP 5: You will now have two A/B units.

STEP 6: Repeat Steps 1-5 to make a total of (4) A/B units.

IMPORTANT: Trim each HST to 3" x 3".

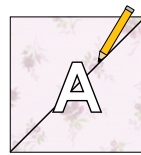

Step 1

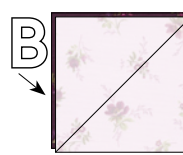

Step 2



Step 3

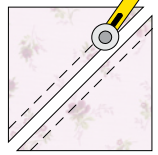

Step 4

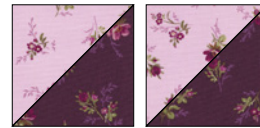

Step 5
Make (4)

BASKET BLOCKS

STEP 1: Sew C triangles to top and left side of A/B HST, aligning right angles with HST. Press open.

STEP 2: Align 45° lines on ruler (*highlighted in cyan*) with HST seams, and trim diagonal seam allowance to ¼" past intersection.

STEP 3: Place Basket Handle Appliqué on pieced unit, RST. Because both units are cut on the bias, be careful not to stretch fabric as you sew them together along diagonal. Press open. Unit should measure 5½" x 5½".

STEP 4: Sew Fabric C basket base left square to the end of a Fabric D beside basket rectangle. Press open.

STEP 5: Sew basket base left unit to bottom of basket unit, noting orientation. Press toward basket base unit.

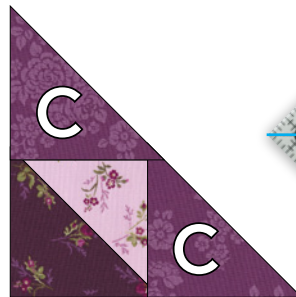

Step 1

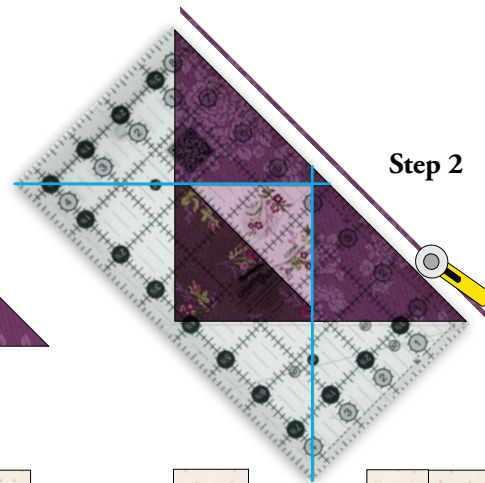

Step 2



Step 3



Step 4



Step 5

STEP 6: Sew Fabric C **basket base right** rectangle to the end of a Fabric D **beside basket** rectangle. Press open.



Step 6

STEP 7: Sew basket base right unit to right side of basket unit, noting orientation. Press toward basket base right unit.



Step 7

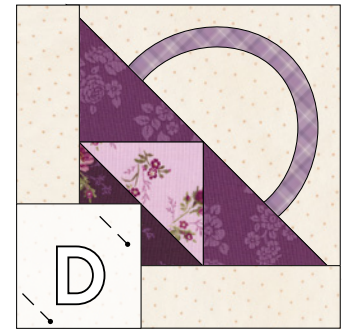

Step 8

STEP 8: Place (1) D $2\frac{1}{2}'' \times 2\frac{1}{2}''$ **below basket** square in corner, RST, as shown. Pin carefully at corners.

STEP 9: Turn block over and draw a 45° line from corner to corner, **making sure drawn line intersects the basket point**. Pin well around drawn line. Sew **on** drawn line.

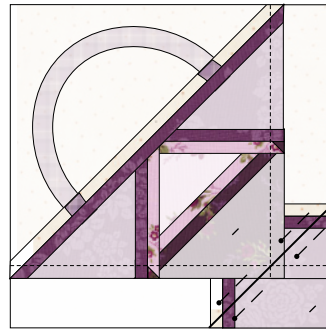

Step 9

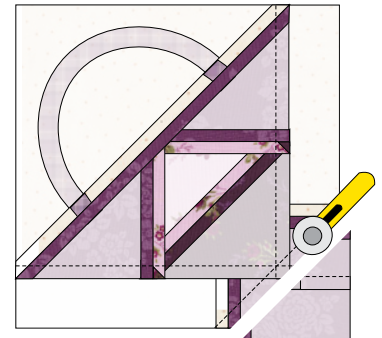

Step 10

STEP 10: Trim seam allowance to $\frac{1}{4}''$. Press toward D.

Repeat to make a total of (4) Basket Blocks. Each block should measure $6\frac{1}{2}'' \times 6\frac{1}{2}''$.

ASSEMBLE TABLE RUNNER

Arrange blocks as shown. Sew **sashing** strip between two blocks; press toward sashing. Sew sashing strips to each side of **cornerstone**; press toward sashing. Sew pieced blocks and sashing unit together; press toward sashing unit. Sew one appliqué unit to each end as shown; press toward pieced blocks.

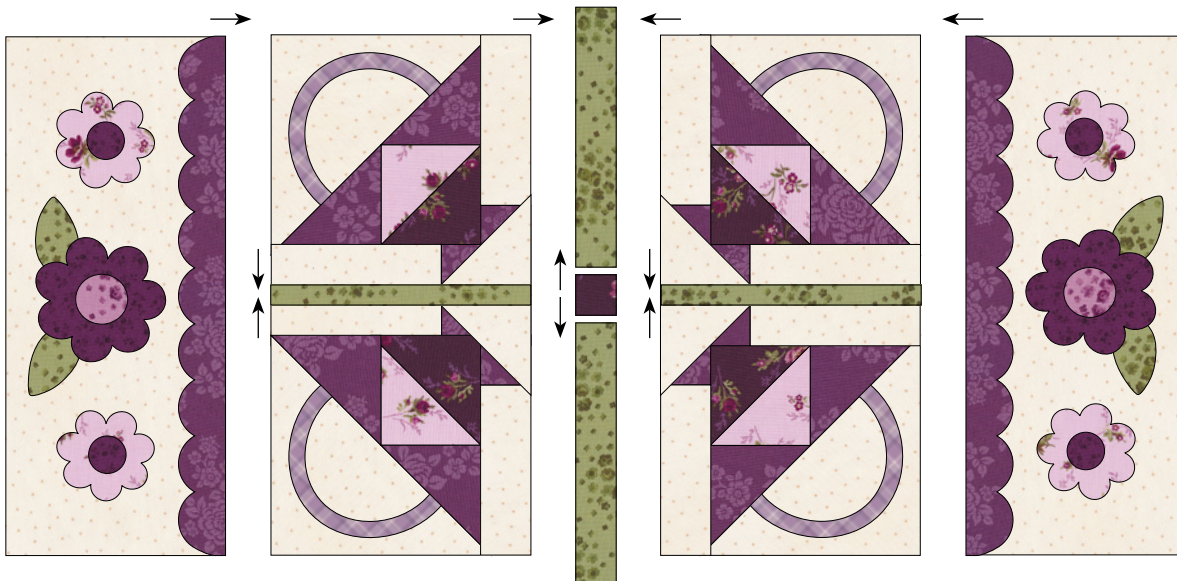

FINISH TABLE RUNNER

Layer top, batting, and backing. Quilt as desired.

Piece **binding** into one long strip. Fold in half lengthwise, wrong sides together, and press. Line up raw edges of the binding with the raw edge of the table runner. Sew binding to the front side of the table runner, starting at any side. Turn the binding over and hand stitch to the back of the table runner.

PINT SIZE TABLE RUNNER

— *May* —

© 2022 Shabby Fabrics

Assembly Diagram

With the exception of the center flower (5) and leaves (3 and 4),
all shapes are symmetrical;
diagram can be used for tracing and for placement

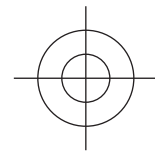

Align bullseye marks ⊕ on page 1 with
bullseye marks ⊕ on page 2, then tape
pages together

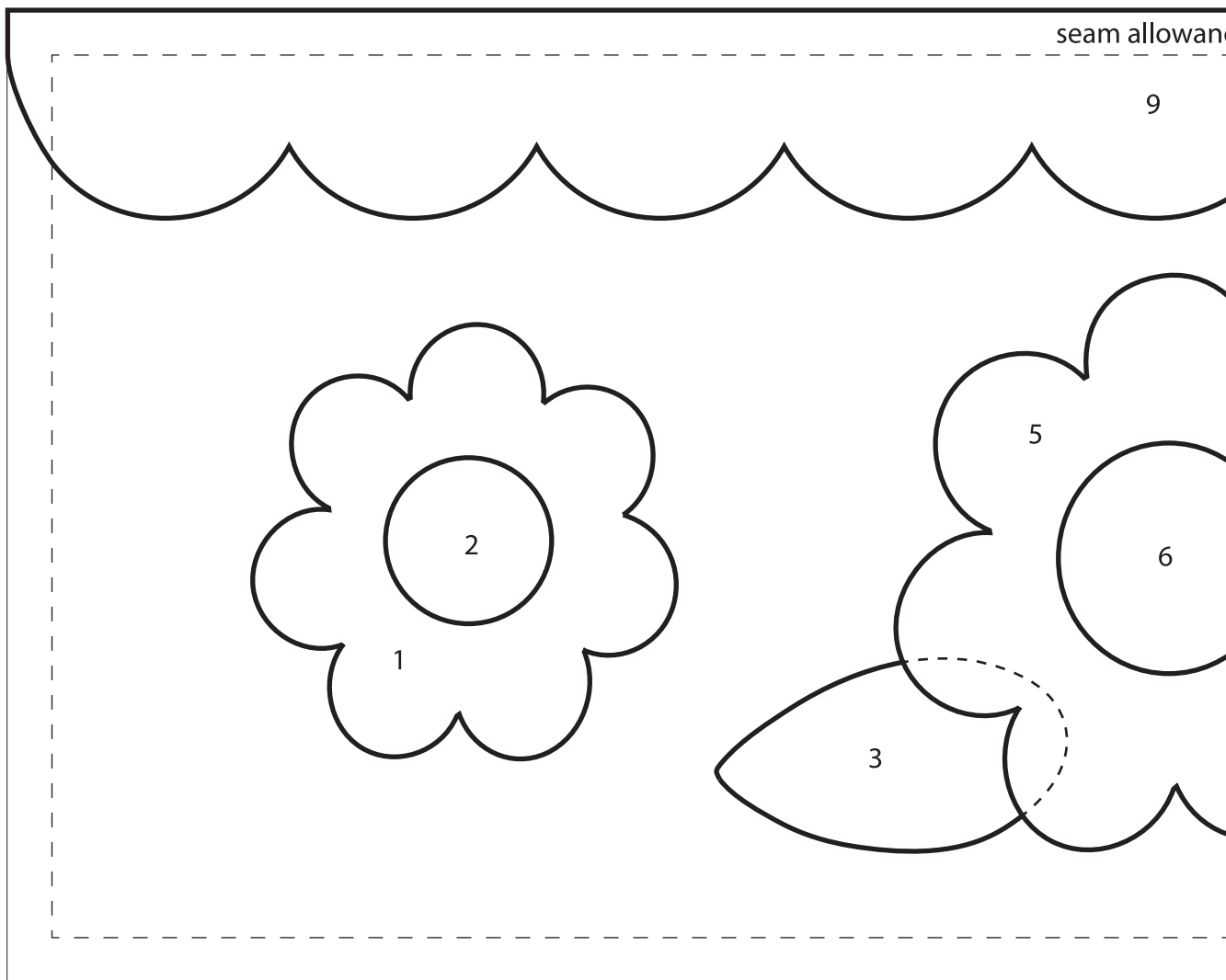

ShabbyFabrics.com

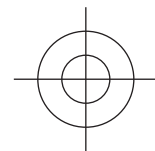

For personal use ONLY, not for commercial production. No part of this pattern may be reproduced, shared, or distributed in any form unless given express written consent by Shabby Fabrics. Not to be used with any online classes or video tutorials other than the official Shabby Fabrics tutorial. All designs, photographs, and images are protected by federal copyright law. All rights reserved.

PINT SIZE TABLE RUNNER

— *May* —

© 2022 Shabby Fabrics

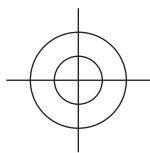

Assembly Diagram

With the exception of the center flower (5) and leaves (3 and 4),
all shapes are symmetrical;
diagram can be used for tracing and for placement

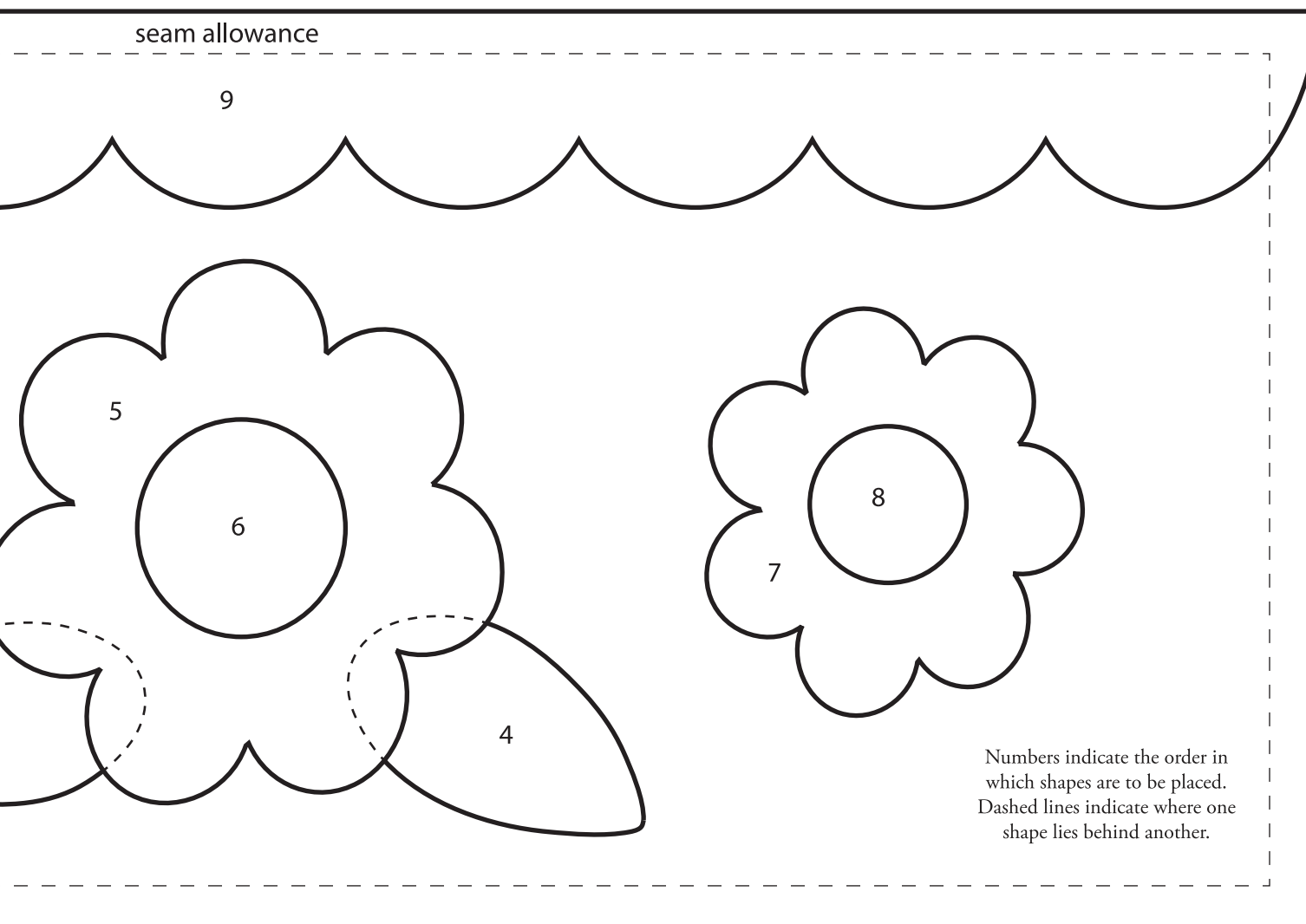

Numbers indicate the order in
which shapes are to be placed.
Dashed lines indicate where one
shape lies behind another.

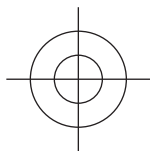

ShabbyFabrics.com

For personal use ONLY, not for commercial production. No part of this pattern may be reproduced, shared, or distributed in any form unless given express written consent by Shabby Fabrics. Not to be used with any online classes or video tutorials other than the official Shabby Fabrics tutorial. All designs, photographs, and images are protected by federal copyright law. All rights reserved.

PINT SIZE TABLE RUNNER

— *May* —

© 2022 Shabby Fabrics

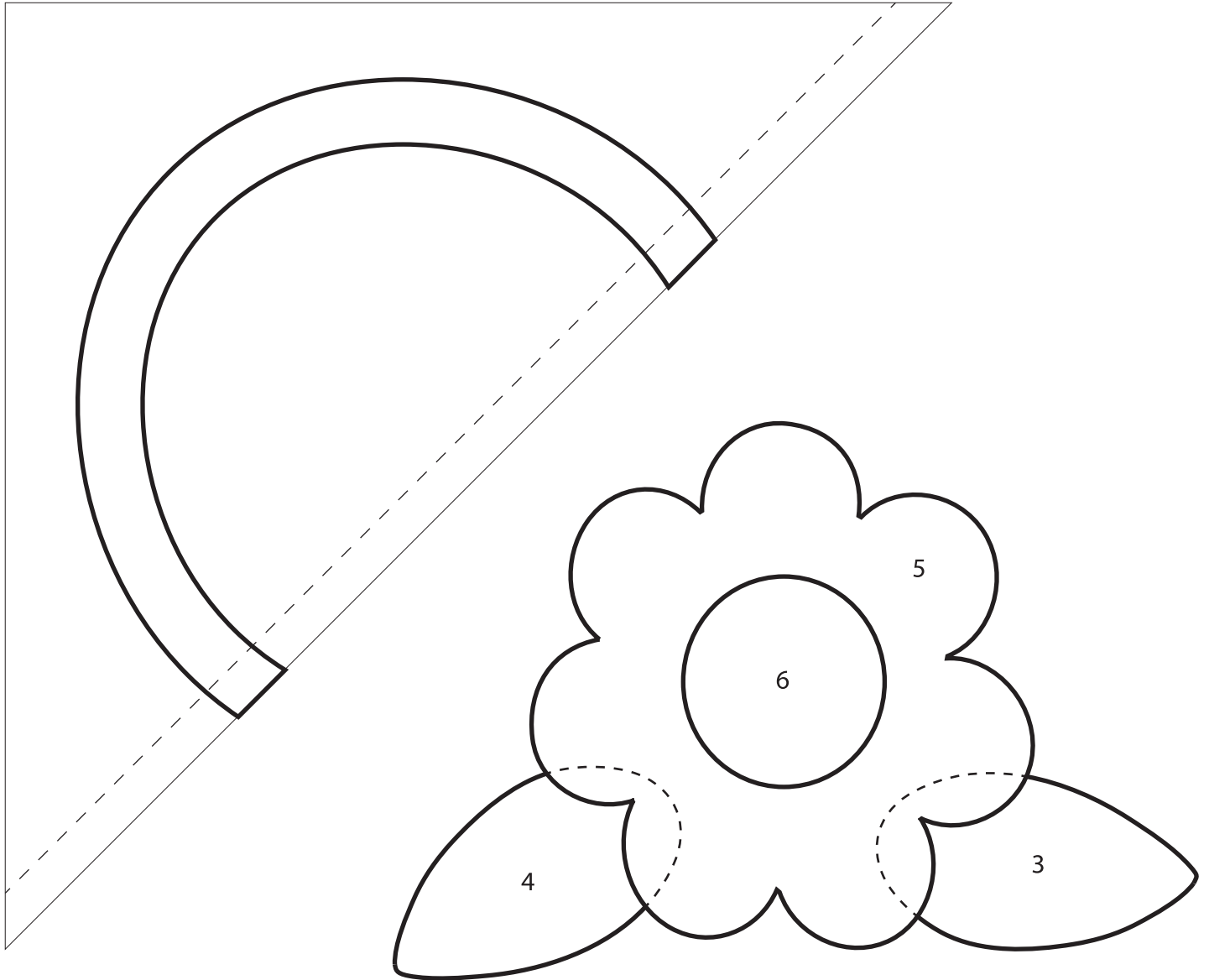

center flower and leaves
reversed for tracing

ShabbyFabrics.com

For personal use ONLY, not for commercial production. No part of this pattern may be reproduced, shared, or distributed in any form unless given express written consent by Shabby Fabrics. Not to be used with any online classes or video tutorials other than the official Shabby Fabrics tutorial. All designs, photographs, and images are protected by federal copyright law. All rights reserved.